

Milling - Face Milling - Cutter

Cutters for ONMU

Cutting Angle: 45°
16 Corner Negative

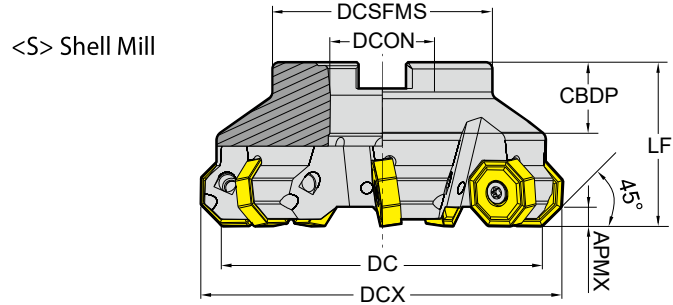

ZAFP : Effective Number of Cutting Edges
CICT : Number of Inserts
CBDP : Connection Bore Depth

: p. 116 Unit: mm

Series	APMX	Designation	EDP 1700..	DC	DCX	ZAFP	LF	TYPE	DCON	CBDP	DCSFMS	PCD1	PCD2	
ONMU 0806	5.5	F45 - ONMU08 - D63Z5S22	0493	63	75	5	40	Shellmill	22	22	49	-	-	●
		F45 - ONMU08 - D80Z6S27	0494	80	92	6	50		27	25	58	-	-	●
		F45 - ONMU08 - D100Z7S32	0495	100	112	7	50		32	26	67	-	-	●
		F45 - ONMU08 - D125Z8S40 - WOC	0496	125	137	8	63		40	32	87	-	-	X
		F45 - ONMU08 - D160Z10S40 - WOC	0497	160	172	10	63		40	32	107	66.7	-	X
		F45 - ONMU08 - D200Z12S60 - WOC	0498	200	212	12	63		60	40	130	101.6	-	X
		F45 - ONMU08 - D315Z16S60 - WOC	0499	315	327	16	63		60	40	220	101.6	177.8	X

▶ ONHU is Available for Wiper Insert